



Developing and working near our pipes and apparatus

Affinity Water Guidance Document

Table of Contents

Contents

Table of Contents.....	2
1 Introduction	3
2 Location of our pipes and apparatus.....	4
3 Working near our assets.....	5
4 Developments near our assets	9
Contact us	10

1 Introduction

1.1 Working near our assets

Whether you are developing or working in any land (which may include a street), you will need to ensure that any such work or development is a safe distance away from our pipes and apparatus. This guidance note sets out what those safe distances are, according to the size and purpose of our water pipe/apparatus and the type of building, development or works proposed.

The scope of this guidance includes all water pipes, network apparatus and associated telemetry systems associated with our network. It applies to temporary works such as trial holes and other excavation activities in and around our apparatus as well as the positioning of permanent building and development works.

1.2 Related Documents

Useful Information. Developments affecting AWL Assets. (www.affinitywater.co.uk/developing-your-land.aspx)

HSG47 – Avoiding danger from Underground Services (www.hse.gov.uk)

NJUG Guidelines Volume 1 on the positioning and colour coding of underground utilities' apparatus (www.streetworks.org.uk)

NJUG Guidelines Volume 4; Guidelines for the Planning, Installation and Maintenance of Utility Apparatus in the Proximity to Trees (www.streetworks.org.uk)

2 Location of our pipes and apparatus

We provide a mapping website for contractors and organisations, which allows online access to our apparatus mapping information:

- If you work for an organisation that holds Public or Infrastructure Body status (as defined by Schedule 1 of the Utilities Contracts Regulations 2006) then access to our mapping website is free and you will not need to provide us with a copy of your organisation's Ordnance Survey (OS) licence.
- If you work for an organisation that does not hold either Public or Infrastructure Body status, you will need to pay a one-off set-up charge of £35 + VAT to access the mapping website and we will first need to obtain a copy of your organisation's OS licence. This confirms we can make Ordnance Survey's copyright mapping available to you.

More information and access to our NRSWA mapping website is available here:

<https://www.affinitywater.co.uk/mapping.aspx>

Alternatively, you can email our Mapping Team on: maps@affinitywater.co.uk

If you are an individual (not a contractor or organisation) and wish to obtain access to our apparatus mapping information, you should email our Mapping Team on:

maps@affinitywater.co.uk

Please note that the maps will show the approximate locations of our apparatus as they are recorded and may not show the location of private pipes or service connections. You should consider using an independent contractor to carry out your own survey of the relevant area.

3 Working near our assets

If you intend to carry out utility works in private land, highways, pavements or verges that may contain our assets, you will need to ensure that any such works are carried out within a safe distance from our pipes and apparatus so to avoid damage to these assets.

In order to work safely in and around our pipes and apparatus and ensure this apparatus is protected and access maintained now and into the future, the following requirements shall be met:

1. If you are carrying out works that require our apparatus to be moved to ensure the requirements in this document are met then please contact dx@affinitywater.co.uk with the details of your development.
2. If you are working in and around our apparatus in accordance with the requirements of this guidance then please contact maps@affinitywater.co.uk with details of your works
3. Guidance issued in HSG47 shall be taken as the minimum standard for the works.
4. For works in and around mains greater than or equal to 300mm a comprehensive risk and method statement (RAMS) shall be provided at least 10 working days before commencement of any works - the particular department that will process this information will be advised at the time of application. The RAMS shall incorporate the following requirements and be specific to the works to be carried out.
 - a) Scope of works and risks associated with the work
 - b) Measures to be taken to mitigate any risks
 - c) Resources and competencies of resource undertaking the work
5. Typically water mains are laid at a depth of 900mm. The exact depth of a specific asset may be unavailable but can vary between 750mm and 1500mm as shown in Figure 1. There may however be instances where pipelines cross other utilities' plant, roads, railways or rivers where our pipes could be significantly deeper, occasionally mains are laid at shallower depths. Service pipes normally have a depth of 750mm but again this may vary and their position can be inferred from the position of stop taps and meter box covers. In all situations the potential existence of small supply pipes should always be anticipated and all care taken to ensure they are located prior to the use of mechanical equipment.

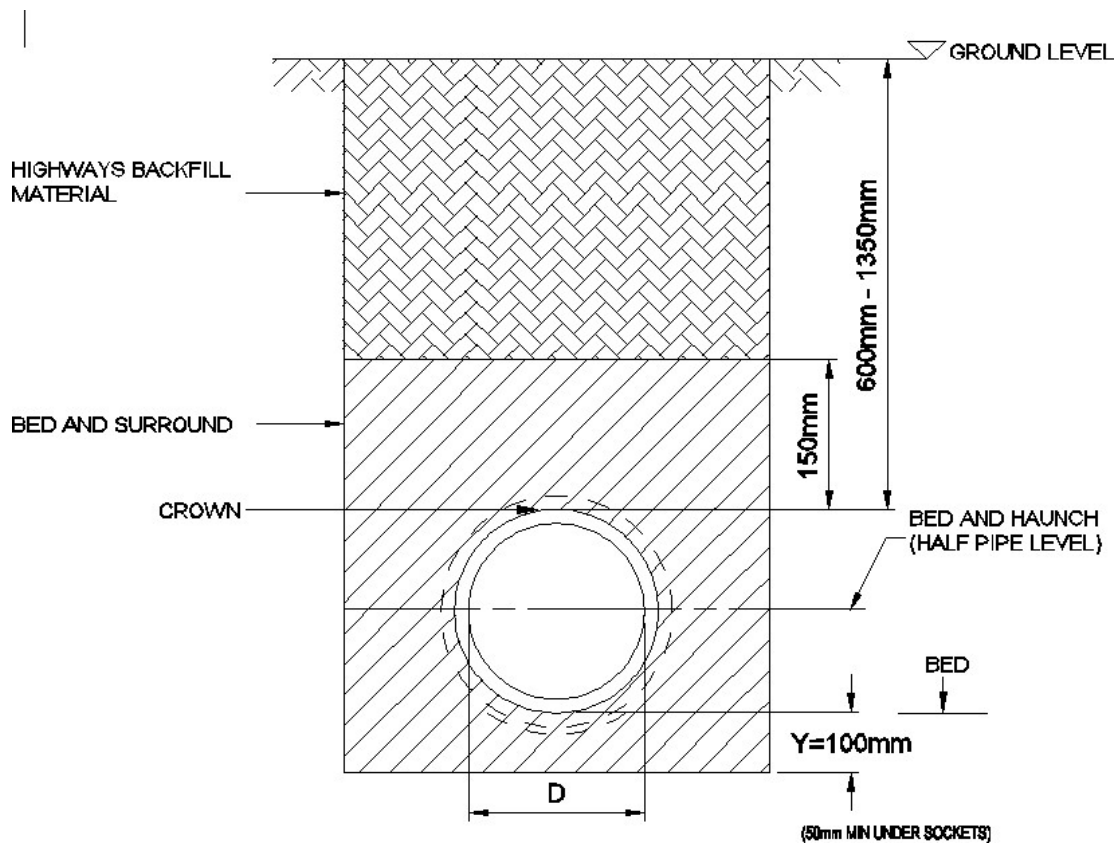

Figure 1 Diagram Showing the Range of Depths for Affinity Water's Pipes

6. No mechanical excavators or power tools are to be used within 500mm of any main or other asset. Final exposure of the main by horizontal digging is preferred.
7. Where excavations of trenches adjacent to any of our assets affect its support or restraint, our asset must be adequately restrained to prevent movement in any direction. Water mains are pressurised and could fail, particularly if excavation removes support to thrust blocks on bends and fittings. The proposed restraint design must be provided to maps@affinitywater.co.uk for review.
8. Where other utility plant crosses our pipelines and assets, these should cross perpendicular to the pipeline where possible. Crossings of ducts, pipelines etc should pass below our assets with a minimum cover of 300mm, when in a trench crossing. Where large numbers of ducts, large pipelines cross using a tunneling technique then the requirement for cover is greater due to the greater risk and we should be consulted. Where other utilities apparatus cross below a large pipeline (300mm or greater) the risk of damage to this apparatus is great should the pipe fail. In this instance, a minimum cover between apparatus shall be 600mm
9. Where electrical cables cross or run parallel a ferrous pipeline (>300mm) an assessment is to be made as to whether cathodic protection of the pipeline is required.
10. Where a water pipe is being crossed underneath then the pipe shall be supported over its exposed length.

11. Where a trench is excavated that crosses or is parallel to the line of any of our assets, the backfill must be adequately compacted to prevent any settlement which could subsequently cause damage to our assets. It may be necessary to provide our assets with permanent support where it has been exposed over the length of the excavation before backfilling and reinstatement is carried out. Concrete backfill should not be in contact with our assets.
12. Where it is proposed to carry out piling or boring within 15 meters of any of our assets, we should be consulted to enable any affected assets to be surveyed prior to the works commencing and the location/path of the main should be marked out above ground. Where aggressive piling techniques such as driven piling or substantial demolition works are within 10m of our assets, work should not be undertaken without prior notification as additional protection of assets may be required.

If your scheme involves any form of piling:

- The outer surface of the apparatuses that may be affected must be defined at ground level before works commence.
 - Driven piles shall be installed no closer than 15m from the pipe measured between the outside face of the pile and the outside face of the pipe.
 - Bored or augered piles shall be at least three metres or 1.5 times the diameter of the pile, whichever is greater, from the pipe measured between the outside face of the pile and the outside face of the pipe.
 - Piles adjacent to a pipe must be founded at a level not less than 1.5m below the underside of the pipe.
 - All boring operations must be controlled to ensure that the minimum of vibration is transmitted to the pipe
 - Impact hammer or vibrating hammer piles need to be considered on an individual basis, dependent on the nature and condition of the pipe.
 - Piles forced or otherwise jacked into place can cause abnormal loadings on pipes below and should be subject to specific assessment.
13. During construction work, where heavy plant needs to cross a pipeline or other asset, we must be made aware of the specific crossing points and they shall be suitably protected where required. Protection may include restricting the number of crossings. These crossing points should be clearly marked on site and crossings at other locations must be prevented. Positioning of static plant should not be positioned within 5m of our assets.
 14. No other below ground assets should be laid directly along the line of our assets irrespective of clearance, in accordance with NJUG, see Figure 2 below for details.. No manhole or chamber shall be built over or adjacent to any AWL assets in accordance with NJUG Guidelines volume 1. Clear distances to above ground structures are set out in table 1 in section 4.

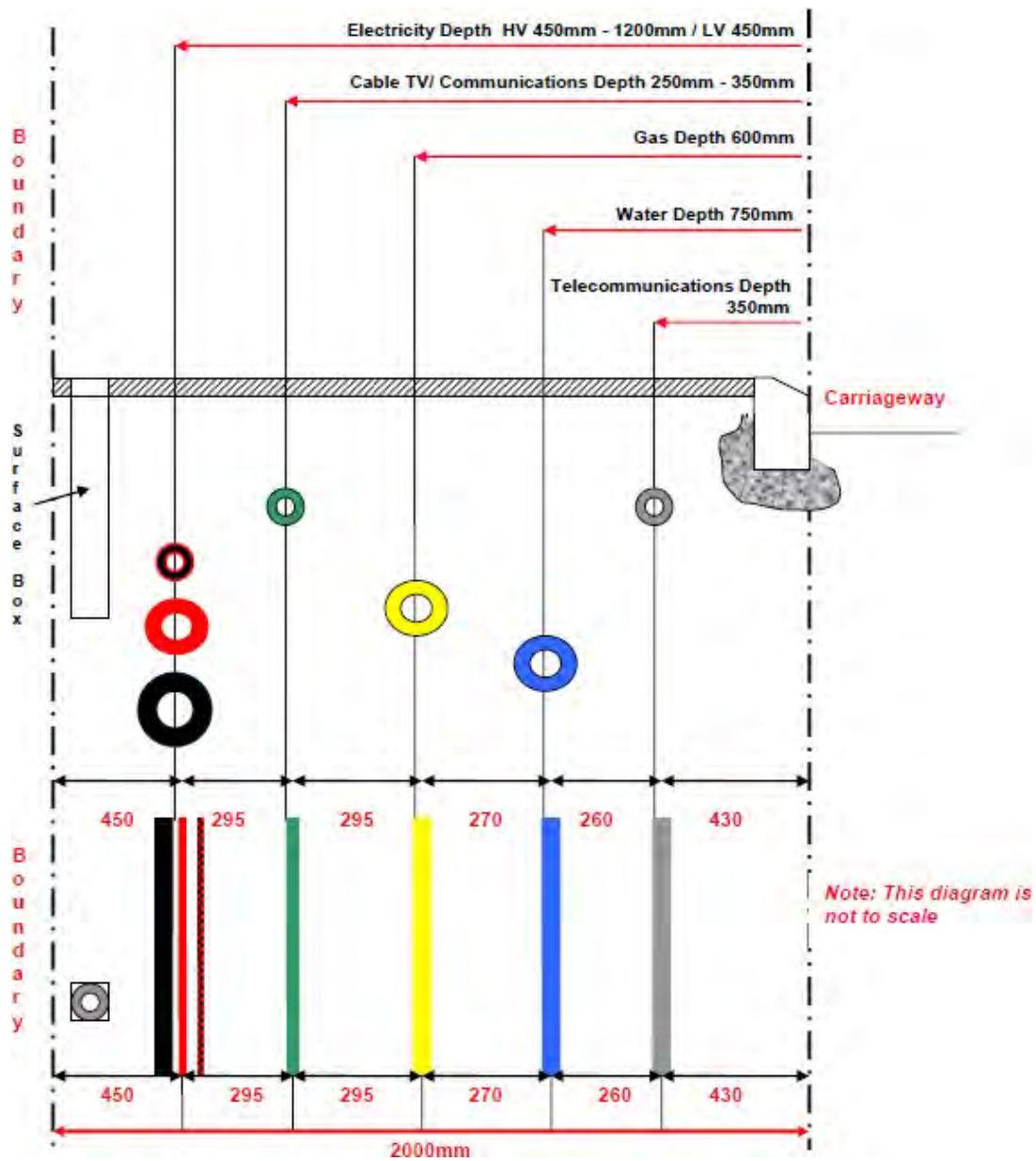

Figure 2 Recommended Positioning of Utility Apparatus in a 2 metre Footway

15. Damage to our assets may include damage to coatings or wrappings, even to a minor extent. Where damage occurs we must be notified and the trench left open until the damage has been inspected and the necessary repairs have been carried out, at the cost of the third party responsible. The necessary remedial work will be recharged.

4 Developments near our assets

4.1 General information

If you intend to build or develop on private land, you may be able to continue with your proposed development provided you build a safe distance from our water pipes and apparatus. This is to ensure we have access to our assets at all times, including access for any such plant or machinery necessary for carrying out maintenance or repair works.

1. Structures (permanent or temporary) are not permitted directly adjacent or over our assets. Our standard distances to structures are shown below.

2. No structure is allowed within two metres of a public water main and this distance may increase where necessary to protect our mains as stated below.

Table 1 standard distances to structures for differing pipe diameters

Diameter of Water Main	Protection Width
Less than 150mm	4m (2m from the centre line either side of the water main)
150mm – 450mm (6” – 18”)	6m (3m from the centre line either side of the water main)
>450mm (18”)	8m (4m from the centre line either side of the water main)

3. It may be necessary to adjust the finished level of any surface boxes which may fall within a proposed construction. Ground level cannot be raised above a height of 1500mm or reduced below a height of 750mm above the crown of the pipe. If there is no other option the pipe can be relocated, however this will be at the third party's expense. Assets including but not limited to stop taps meters, valves and hydrants shall not be damaged, buried or otherwise rendered inaccessible or inoperable as a result of the works. Minor reduction in existing levels may result in conflict with assets such as valve spindles or tops of hydrants housed under the surface boxes. Checks should be made during site investigations to ascertain the level of such assets in order to determine any necessary alterations in advance of the works.

4. With regard to any proposed resurfacing works, we must be contacted to arrange a site inspection to establish the condition of any assets in the nature of surface boxes or manhole covers and frames affected by the works. We will then advise on any measures that must be taken in the event of this and a proportionate charge will be made.

5. The erection of posts must not be either directly over, or within 1.0 meter, of valves and hydrants so they can be safely operated.

4.2 Planting restrictions

Set out below are the recommendations for planting in close proximity of our assets. General guidance is provided by NJUG volume 4; Guidelines for the Planning, Installation and Maintenance of Utility Apparatus in the Proximity to Trees. Mature root systems and canopies of any plants should not encroach within the recommended distances specified in the notes below:

1. No shrubs or bushes should be planted within 2 metres of the centre line of a water pipe or apparatus, including water meter boxes.
2. The following trees and those of a similar size, whether deciduous or evergreen should not be planted within 6 metres of our assets: Ash, Beech, Birch, Conifers, Elm, Horse Chestnut, Lime, Oak, Sycamore, Apple and Pear trees.
3. Trees with extensive root systems such as Poplar and Willow trees should not be planted within 12 metres of our assets.
4. In certain circumstances, both the Company and landowners may wish to plant shrubs/bushes in close proximity to our assets for screening purposes. This should only be done once prior approval by us has been provided. The following are shallow rooting and are suitable for this purpose: Blackthorn, Broom, Cotoneaster, Elder, Hazel, Laurel, Privet, Quick Thorn, Snowberry and most ornamental flowering shrubs.

Contact us

Any requirements in this guidance note relating to notification, contact, consent or review should be directed to Development Experience at dx@affinitywater.co.uk: